

PG680

Reservdelar

Spare parts

Ersatzteile

Pieces de rechange

Piezas de repuesto

Ricambi

Peças sobresselente

No.	Pos.	Description	No.	Pos.	Description
502 53 69-01	A3	SHAFT	502 55 18-01	A2	SIDE WALL
502 53 39-01	B2	SILICON SPRING	502 55 21-01	A2	CHAIN RING
502 53 40-04	A3	SPACER	502 55 35-01	A3	BELT
502 53 40-05	A3	RUBBER RING	502 55 58-01	B1	LOWER CHASSIS
502 53 40-06	A3	DRIVE HUB	504 71 71-01	C3	FILTER
502 53 40-14	A3	SPACER	504 71 72-01	C2	FERRITE
502 53 43-01	A3	SILICONE RING	504 72 63-03	A1A3	SPACER
502 53 44-01	A3	HEAD LOCK	504 72 63-04	A1	SPACER
502 53 48-01	A2	SEAL RUBBER KIT	504 72 77-07	B1	SPACER
502 53 52-01	C5	MAIN MOTOR	504 72 78-01	A3	COVER PLATE
502 53 56-01	A1	GEAR BOX	504 72 79-01	A3	PLATE
502 53 57-01	C5	PIANETARY MOTOR	504 72 80-01	A3	SEAL
502 53 65-01	A3	PULLEY	504 72 81-01	A2	RETAINER PLATE
502 53 66-01	A3	SHAFT WITH KEY	504 72 82-01	A2	RETAINER PLATE
502 53 67-01	A3	PULLEY SHAFT	504 72 88-01	A2	SPACER RING
502 53 68-01	A3	PULLEY	504 72 90-01	A1	LIFTING LUGS
502 53 70-01	A3	BEARING HOUSING	504 72 93-01	A1	PLATE
502 53 71-01	A2	BEARING HOUSING	504 72 95-01	A1A2A3	WASHER
502 53 72-01	A2	BEARING HOUSING	504 72 97-01	B1	CHASSIS PIN
502 53 73-01	A3	HOUSING	504 72 98-02	A1	EXTRACTION CAMLOCK
502 53 77-01	A3	RETAINER PLATE	504 72 99-01	A2	BELT TENSIONER
502 53 78-01	A3	COVER PLATE	504 73 86-01	C4	SWITCH
502 53 79-01	A2	COVER PLATE	504 73 87-01	C4	SWITCH BODY
502 53 81-01	A1	BRACKET	504 73 88-01	C4	RESET BUTTON
502 53 82-01	A3	FRAME	504 73 89-01	C4	BUTTON BODY
502 53 85-01	A1	VELCRO	504 73 90-01	C4	POWER BUTTON
502 53 87-01	A3	BEARING	504 73 94-01	C4	EMERGENCY STOP BUTTON
502 53 88-01	A3	CIRCLIP	504 73 95-01	C4	BUTTON BODY
502 53 89-01	A2	MAIN BEARINGS	504 73 96-01	C4	GREEN LIGHT INDICATOR
502 53 90-01	A2	CIRCLIP	504 73 97-01	C4	RED LIGHT INDICATOR
502 53 91-01	A3	BEARING	504 74 03-01	C5	CABLE CE
502 53 93-01	A3	BEARING	504 74 03-02	C5	CABLE UL
502 53 95-01	A3	BEARING	504 74 13-01	B2	HOUR METER
502 53 96-01	A3	CIRCLIP	504 74 73-01	A1B2	WASHER
502 53 97-01	A3	OIL SEAL	504 74 83-01	A1	WASHER
502 53 98-01	A3	SEAL	504 74 84-01	A3	SCREW
502 53 99-01	A2	WAVE WASHER	504 74 88-01	A3	SCREW
502 54 24-01	A1	SPROCKET	504 74 89-01	A3	SCREW
502 54 25-01	C3	FREQUENCY INVERTER	504 74 96-03	A3	SPRING WASHER
502 54 26-01	C3	FREQUENCY INVERTER	504 75 02-01	A2	SCREW
502 54 29-01	C4	POTENTIOMETER	504 75 06-01	B1	NUT
502 54 33-01	C4	FACE PLATE	504 75 07-01	B1	SCREW
502 54 36-01	C3	CONTACTOR BLOCKS	504 75 13-01	B1	SCREW
502 54 37-01	C3	CIRCUIT BREAKER	504 75 14-01	B1	WASHER
502 54 38-01	C3	EARTH TERMINALS	504 75 20-01	B1	SCREW
502 54 39-01	C3C4	GLAND	504 75 81-01	C3	SPACER
502 54 41-01	B2	VENT KIT	504 75 82-01	C4	EARTHING PLATE
502 54 42-01	C2	CONTROL PANEL LOOM	504 75 84-01	C3	CLAMP
502 54 46-01	C4	CONTROL PANEL	504 76 25-01	C3	CONNECTOR
502 54 47-01	B1	UPPER CHASSIS	505 46 40-01	C3	NXS DISPLAY PANEL
502 54 47-07	B1	KICKER BAR	515 98 41-01	B2	SILICONE WASHER
502 54 47-11	B1	GAS STRUT	516 05 68-01	A1	FAN COVER
502 54 49-02	B1	HANDLE BAR WITH LEVER	516 05 70-01	A1	FAN
502 54 49-05	B1	ADJUSTER	516 05 71-01	A1	PIN
502 54 49-20	B1	HANDLE BAR	516 05 72-01	A1	FAN COVER
502 54 49-22	B1	TUBBING GRIP	516 05 73-01	A1	FAN
502 54 49-23	B1	COVER	516 05 74-01	A1	PIN
502 54 49-25	B1	HANDLE BAR MOUNTS	516 05 75-01	C2	CABLE CE
502 54 49-26	B1	CONTROL CABLE MOUNTS	516 05 75-02	C2	CABLE UL
502 54 49-27	B1	SPRING	516 05 76-01	C2	CABLE CE
502 54 50-01	B1	SOLID WHEEL	516 05 76-02	C2	CABLE UL
502 54 58-01	A3	HOLDER DISC	516 05 77-01	C2	CONNECTION CABLE CE
502 54 80-01	A3	SPRING STEEL SYSTEM	516 05 77-02	C2	CONNECTION CABLE UL
502 54 82-01	A3	REPLACEMENT SPRING	516 05 78-02	A1	ADHESIVE SEAL
502 54 86-01	A1	RUBBER SKIRT	516 05 81-01	A3	SHAFT
502 54 98-01	A3	PULLEY	516 05 84-01	A3	SEAL
502 55 09-01	A2	TOP PLATE	516 05 85-01	A3	SEAL
502 55 10-01	A3	BOTTOM PLATE	516 05 90-01	B1	END CAP
502 55 11-01	A1	MOUNTING PLATE	516 05 93-01	B1	PIN
502 55 15-01	A1	GEAR BOX BRACKET	516 05 95-01	B1	ADJUSTER ROD

No.	Pos.	Description	No.	Pos.	Description
516 05 96-01	B1	RUBBER STOPS	732 25 16-01	A1	NUT
516 05 97-01	B1	BUSH	732 25 18-01	A1A2	
516 05 98-01	B2	LOCK		B2C3	NUT
516 06 01-01	C3	RUBBER WASHER	732 25 20-01	A2A3B1	NUT
516 06 04-01	C3	HOUSING	734 11 36-01	C3	WASHER
516 06 05-01	C3	FEMALE PLUG	734 11 52-01	B2	WASHER
516 06 06-01	C3	HOUSING	734 11 54-41	C3	WASHER
516 06 06-02	C3	HOUSING	734 11 63-01	A1A2A3	WASHER
516 06 07-01	C3	FEMALE PLUG	734 11 72-01	A1A3B1	WASHER
516 06 10-01	C3	NXL DISPLAY PANEL	734 11 78-01	A1A3	WASHER
516 06 11-01	C3	RAIL	734 11 86-01	B1	WASHER
516 06 12-01	C5	GLAND	735 11 53-01	B2C3	LOCK WASHER
516 06 13-01	C5	HOOD	735 11 64-01	A1	SPRING WASHER
516 06 14-01	C5	MALE PLUG	735 11 73-01	A1	WASHER
516 06 15-01	C5	MALE PLUG	735 21 53-01	C3	TOOTH WASHER
516 06 16-01	C5	HOOD	735 21 64-01	B2	TOOTH WASHER
516 06 17-01	C5	CABLE CE	735 31 26-00	B1	CIRCLIP
516 06 17-02	C5	CABLE UL	735 31 33-00	A3	CIRCLIP
516 06 18-01	C5	GLAND	735 31 37-00	A3	CIRCLIP
516 06 19-01	C5	TERMINAL BLOCK			
516 06 20-01	C5	TERMINAL BLOCK			
521 88 65-01	B1	SCREW			
521 88 67-01	B2C3	WASHER			
522 44 80-01	A3	HEAD PLATE			
522 44 81-01	A1	COVER ASSY			
522 44 82-01	A1	EXTRACTION PORT ASSY			
522 44 83-01	A1	EXTRACTION MOUNT			
541 40 51-78	B2	SCREW			
543 04 47-66	B2	NUT			
543 04 60-41	B1	END CAPS			
543 04 66-47	A2A3	WASHER			
574 44 08-01	B2	E-BOX KIT			
574 44 10-01	B2	E-BOX DOOR KIT			
574 44 11-01	B2	KEY			
574 44 12-01	C3	PLATE KIT ASSY			
574 44 13-01	C3	CABLE KIT EU			
574 44 13-02	C3	CABLE KIT AU			
574 44 13-03	C3	CABLE KIT US			
721 68 02-51	B1	PIN			
723 13 20-51	A1	SCREW			
723 13 27-51	C5	SCREW			
724 12 93-51	C3	SCREW			
724 13 64-51	B1	SCREW			
724 13 68-51	C5	SCREW			
724 33 70-51	A1	SCREW			
725 23 66-71	A3	SCREW			
725 24 49-76	A3	SCREW			
725 24 51-76	A2A3	SCREW			
725 24 53-76	A1A2A3	SCREW			
725 24 55-76	B1	SCREW			
725 24 60-81	A3	SCREW			
725 24 61-71	B2	SCREW			
725 24 89-76	A2B1	SCREW			
725 24 91-76	A1	SCREW			
725 24 93-76	A3	SCREW			
725 24 97-71	A1	SCREW			
725 25 02-51	A1B1	SCREW			
725 25 15-71	A3	ADJUSTER THREAD ROD			
725 25 32-71	A3	SCREW			
725 25 34-71	A1A2A3	SCREW			
725 53 68-01	C3	SCREW			
725 53 70-51	A3C3	SCREW			
725 53 80-01	C3	SCREW			
725 54 45-01	B1	SCREW			
725 64 55-51	A1	SCREW			
725 64 93-51	A3	SCREW			
728 54 51-05	A1	SCREW			
731 23 20-01	A3	NUT			
731 23 24-01	B1	NUT			
732 25 12-01	C3	NUT			

A1

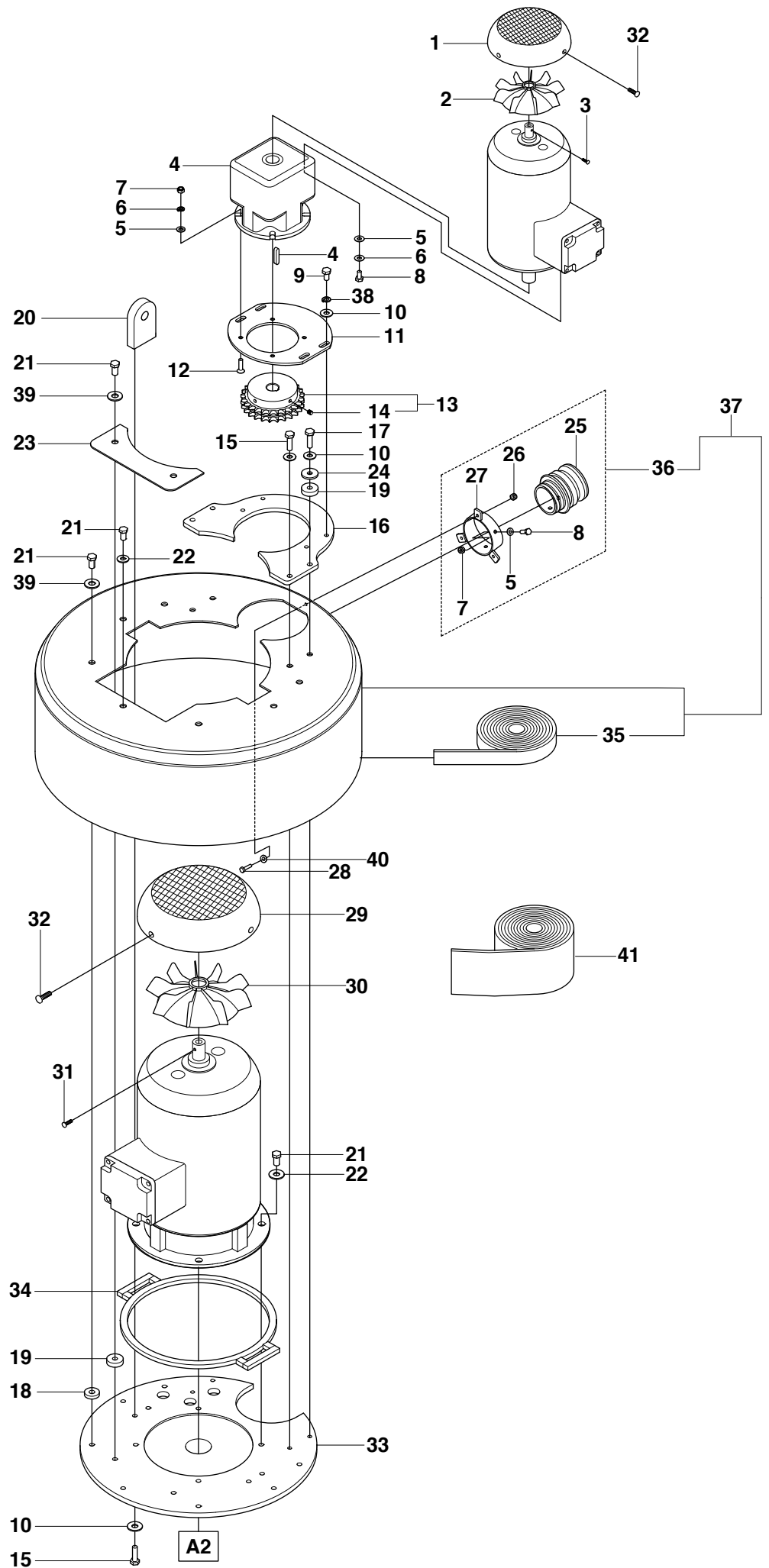

Pos.	Part No.	Description	Quantity	Notes
1	516 05 68-01	FAN COVER	1	
2	516 05 70-01	FAN	1	
3	516 05 71-01	PIN	1	
4	502 53 56-01	GEAR BOX	1	
5	734 11 63-01	WASHER	10	36
6	735 11 64-01	SPRING WASHER	8	
7	732 25 18-01	NUT	6	36
8	725 24 53-76	SCREW	6	36
9	725 24 91-76	SCREW	4	
10	734 11 72-01	WASHER	12	
11	502 53 81-01	BRACKET	1	
12	725 64 55-51	SCREW	4	
13	502 54 24-01	SPROCKET	1	
14	728 54 51-05	SCREW	2	13
15	725 24 97-71	SCREW	6	
16	502 55 15-01	GEAR BOX BRACKET	1	
17	725 25 02-51	SCREW	2	
18	504 72 63-04	SPACER	11	
19	504 72 63-03	SPACER	4	
20	504 72 90-01	LIFTING LUGS	2	
21	725 25 34-71	SCREW	13	
22	734 11 78-01	WASHER	5	
23	504 72 93-01	PLATE	1	
24	504 72 95-01	WASHER	2	
25	504 72 98-02	EXTRACTION CAMLOCK	1	36
26	732 25 16-01	NUT	3	36
27	522 44 83-01	EXTRACTION MOUNT	1	36
28	724 33 70-51	SCREW	3	
29	516 05 72-01	FAN COVER	1	
30	516 05 73-01	FAN	1	
31	516 05 74-01	PIN	1	
32	723 13 20-51	SCREW	7	
33	502 55 11-01	MOUNTING PLATE	1	
34	516 05 78-02	ADHESIVE SEAL	1	
35	502 53 85-01	VELCRO	1	37
36	522 44 82-01	EXTRACTION PORT ASSY	1	37
37	522 44 81-01	COVER ASSY	1	
38	735 11 73-01	WASHER	4	
39	504 74 83-01	WASHER	8	
40	504 74 73-01	WASHER	2	
41	502 54 86-01	RUBBER SKIRT	1	

A2

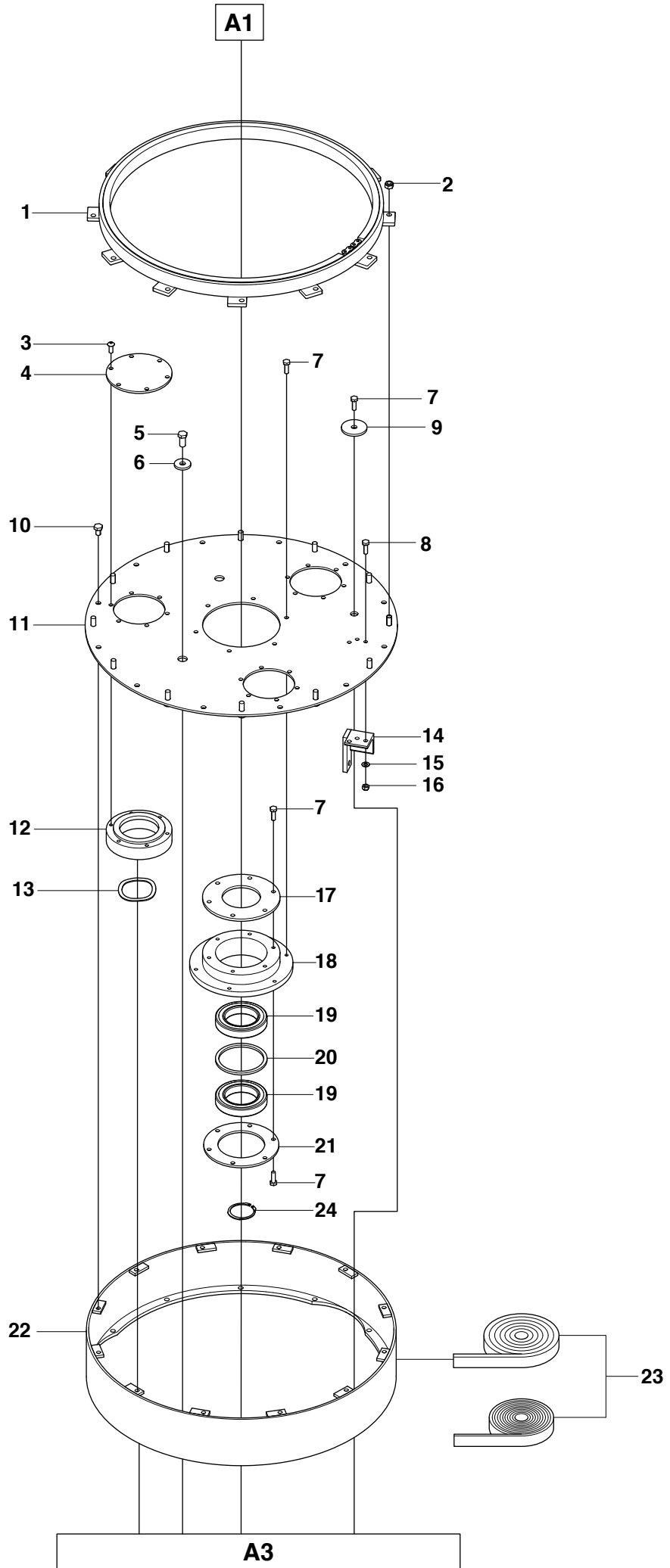

Pos.	Part No.	Description	Quantity	Notes
1	502 55 21-01	CHAIN RING	1	
2	732 25 20-01	NUT	12	
3	504 75 02-01	SCREW	18	
4	502 53 79-01	COVER PLATE	3	
5	725 25 34-71	SCREW	2	
6	504 72 95-01	WASHER	2	
7	725 24 51-76	SCREW	19	
8	725 24 53-76	SCREW	3	
9	543 04 66-47	WASHER	1	
10	725 24 89-76	SCREW	12	
11	502 55 09-01	TOP PLATE	1	
12	502 53 71-01	BEARING HOUSING	3	
13	502 53 99-01	WAVE WASHER	3	
14	504 72 99-01	BELT TENSIONER	1	
15	734 11 63-01	WASHER	3	
16	732 25 18-01	NUT	3	
17	504 72 82-01	RETAINER PLATE	1	
18	502 53 72-01	BEARING HOUSING	1	
19	502 53 89-01	MAIN BEARINGS	2	
20	504 72 88-01	SPACER RING	1	
21	504 72 81-01	RETAINER PLATE	1	
22	502 55 18-01	SIDE WALL	1	
23	502 53 48-01	SEAL RUBBER KIT	1	
24	502 53 90-01	CIRCLIP	1	

A3

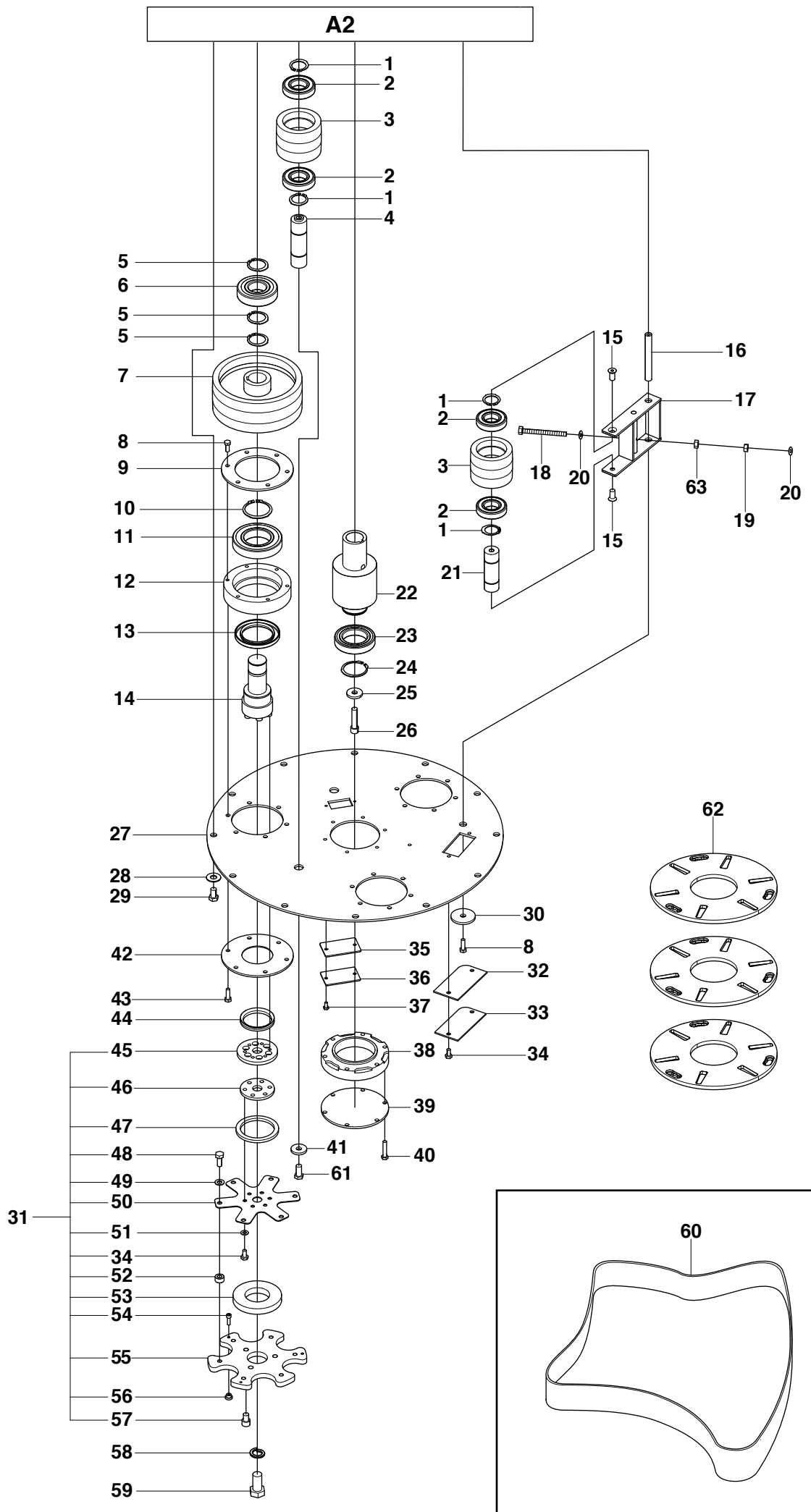

Pos.	Part No.	Description	Quantity	Notes
1	735 31 33-00	CIRCLIP	6	
2	502 53 91-01	BEARING	6	
3	502 53 68-01	PULLEY	3	
4	502 53 67-01	PULLEY SHAFT	2	
5	735 31 37-00	CIRCLIP	9	
6	502 53 93-01	BEARING	3	
7	502 54 98-01	PULLEY	3	
8	725 24 51-76	SCREW	19	
9	502 53 77-01	RETAINER PLATE	3	
10	502 53 96-01	CIRCLIP	3	
11	502 53 95-01	BEARING	3	
12	502 53 70-01	BEARING HOUSING	3	
13	502 53 97-01	OIL SEAL	3	
14	502 53 66-01	SHAFT WITH KEY	3	
15	725 64 93-51	SCREW	2	
16	516 05 81-01	SHAFT	1	
17	502 53 82-01	FRAME	1	
18	725 25 15-71	ADJUSTER THREAD ROD	1	
19	731 23 20-01	NUT	1	
20	734 11 72-01	WASHER	2	
21	502 53 69-01	SHAFT	1	
22	502 53 65-01	PULLEY	1	
23	502 53 87-01	BEARING	1	
24	502 53 88-01	CIRCLIP	1	
25	504 72 63-03	SPACER	1	
26	504 74 88-01	SCREW	1	
27	502 55 10-01	BOTTOM PLATE	1	
28	734 11 78-01	WASHER	12	
29	725 25 32-71	SCREW	12	
30	543 04 66-47	WASHER	1	
31	502 54 80-01	SPRING STEEL SYSTEM	3	
32	516 05 84-01	SEAL	1	
33	504 72 78-01	COVER PLATE	1	
34	725 24 49-76	SCREW	20	
35	516 05 85-01	SEAL	1	
36	504 72 79-01	PLATE	1	
37	725 23 66-71	SCREW	2	
38	502 53 73-01	HOUSING	1	
39	502 53 78-01	COVER PLATE	1	
40	725 24 60-81	SCREW	6	
41	504 72 95-01	WASHER	2	
42	504 72 80-01	SEAL	3	
43	725 24 53-76	SCREW	18	
44	502 53 98-01	SEAL	3	
45	502 53 40-06	DRIVE HUB	3	31
46	502 53 40-04	SPACER	3	31
47	502 53 40-05	RUBBER RING	3	31
48	725 24 93-76	SCREW	18	31
49	734 11 72-01	WASHER	18	31
50	502 54 82-01	REPLACEMENT SPRING	3	31
51	734 11 63-01	WASHER	18	31
52	502 53 40-14	SPACER	18	31
53	502 53 43-01	SILICONE RING	3	31
54	725 53 70-51	SCREW	9	31
55	522 44 80-01	HEAD PLATE	3	31
56	502 53 44-01	HEAD LOCK	9	31
57	504 74 84-01	SCREW	9	31
58	504 74 96-03	SPRING WASHER	3	
59	504 74 89-01	SCREW	3	
60	502 55 35-01	BELT	1	
61	725 25 34-71	SCREW	2	
62	502 54 58-01	HOLDER DISC	3	
63	732 25 20-01	NUT	1	

B1

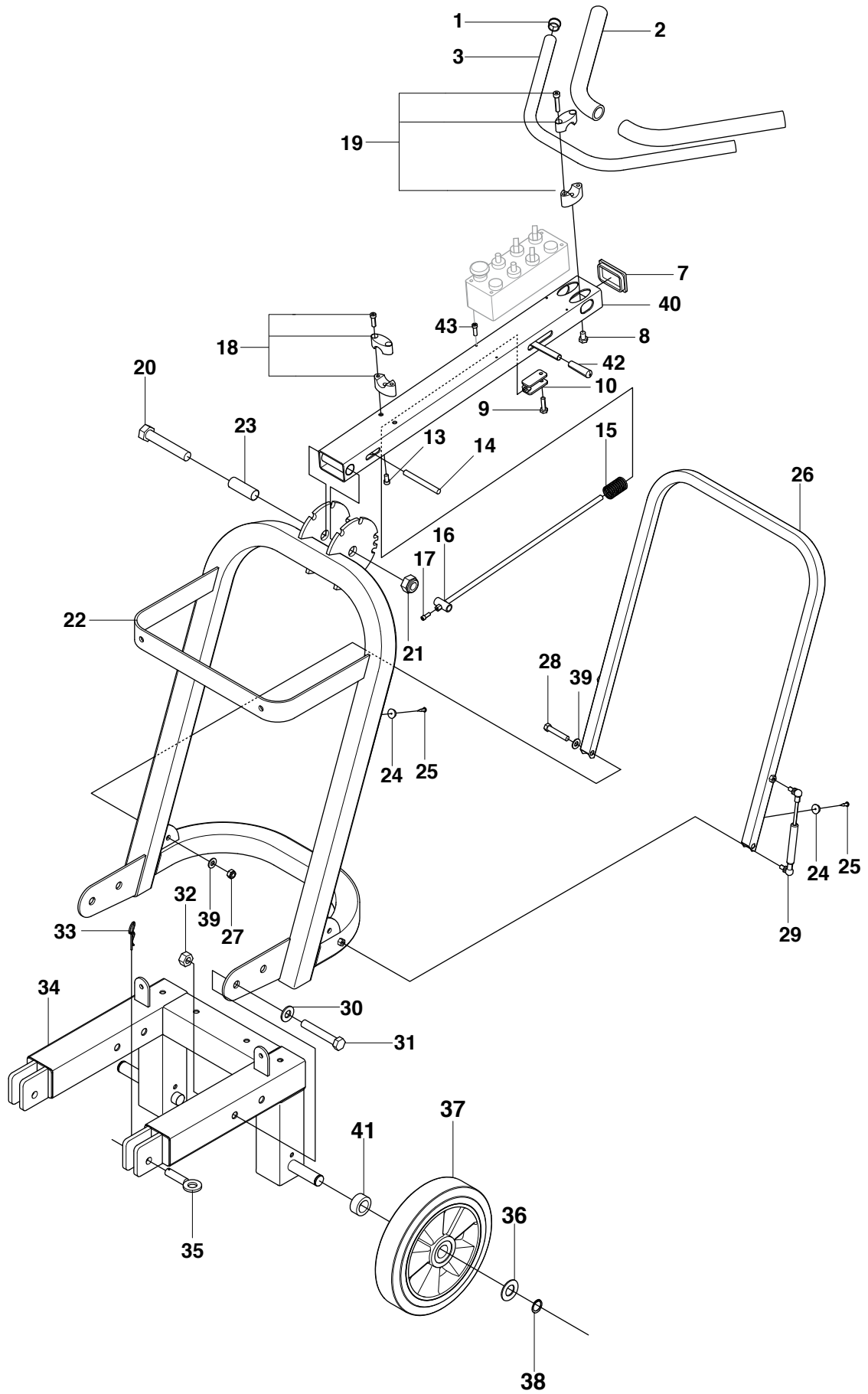

Pos.	Part No.	Description	Quantity	Notes
1	543 04 60-41	END CAPS	2	
2	502 54 49-22	TUBBING GRIP	2	
3	502 54 49-20	HANDLE BAR	1	
7	516 05 90-01	END CAP	1	
8	725 24 89-76	SCREW	2	
9	725 24 55-76	SCREW	1	
10	502 54 49-05	ADJUSTER	1	
13	725 54 45-01	SCREW	2	
14	516 05 93-01	PIN	1	
15	502 54 49-27	SPRING	1	
16	516 05 95-01	ADJUSTER ROD	1	
17	724 13 64-51	SCREW	1	
18	502 54 49-26	CONTROL CABLE MOUNTS	1	
19	502 54 49-25	HANDLE BAR MOUNTS	2	
20	504 75 07-01	SCREW	1	
21	504 75 06-01	NUT	1	
22	502 54 47-01	UPPER CHASSIS	1	
23	516 05 97-01	BUSH	1	
24	516 05 96-01	RUBBER STOPS	4	
25	521 88 65-01	SCREW	4	
26	502 54 47-07	KICKER BAR	1	
27	732 25 20-01	NUT	2	
28	725 25 02-51	SCREW	2	
29	502 54 47-11	GAS STRUT	2	
30	734 11 86-01	WASHER	4	
31	504 75 13-01	SCREW	4	
32	731 23 24-01	NUT	4	
33	721 68 02-51	PIN	2	
34	502 55 58-01	LOWER CHASSIS	1	
35	504 72 97-01	CHASSIS PIN	2	
36	504 75 14-01	WASHER	2	
37	502 54 50-01	SOLID WHEEL	2	
38	735 31 26-00	CIRCLIP	2	
39	734 11 72-01	WASHER	4	
40	502 54 49-02	HANDLE BAR WITH LEVER	1	
41	504 72 77-07	SPACER	2	
42	502 54 49-23	COVER	1	
43	504 75 20-01	SCREW	4	

B2

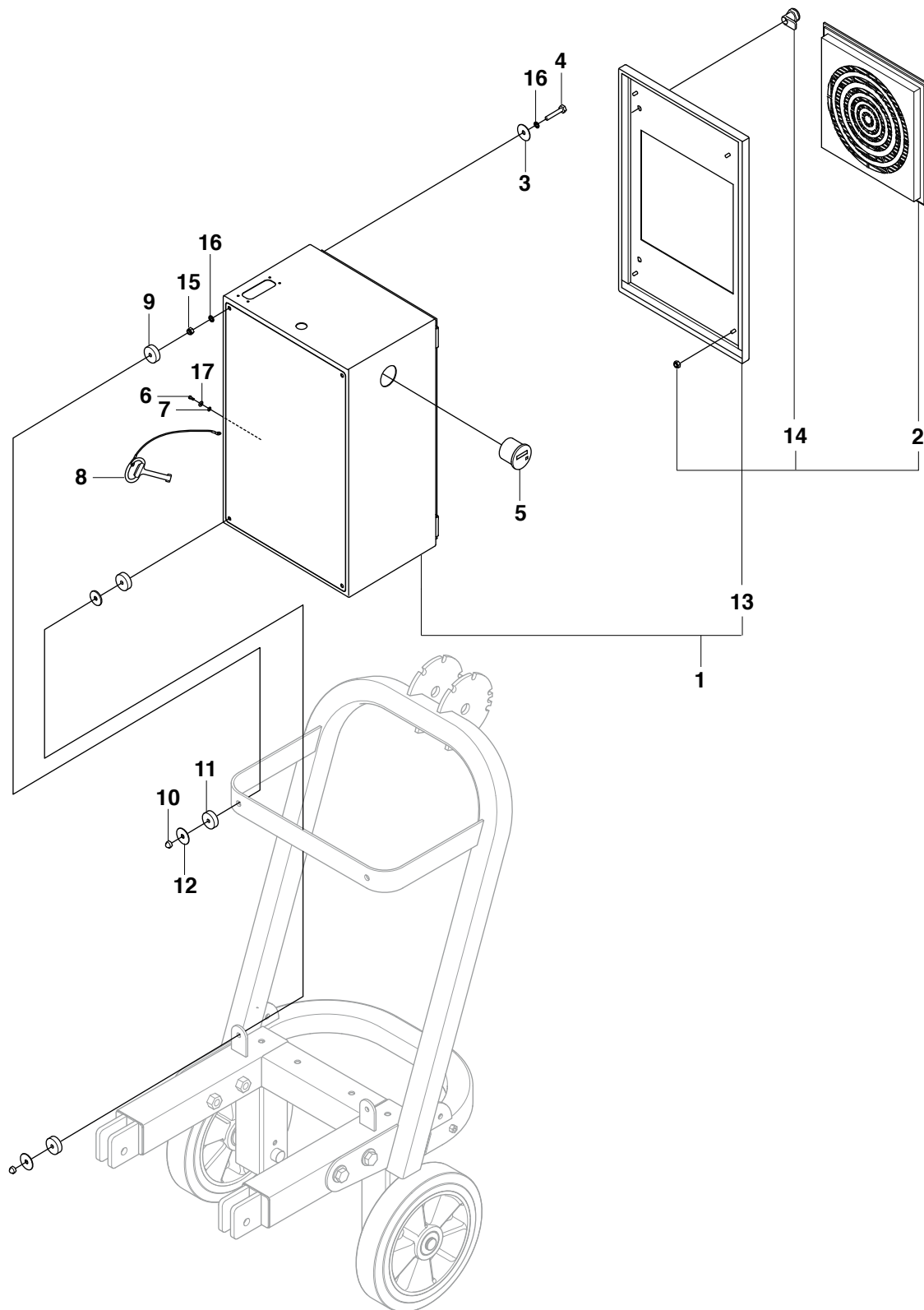

Pos.	Part No.	Description	Quantity	Notes
1	574 44 08-01	E-BOX KIT	1	
2	502 54 41-01	VENT KIT	1	1, 13
3	504 74 73-01	WASHER	4	
4	725 24 61-71	SCREW	4	
5	504 74 13-01	HOUR METER	1	
6	541 40 51-78	SCREW	1	
7	734 11 52-01	WASHER	1	
8	574 44 11-01	KEY	1	
9	502 53 39-01	SILICON SPRING	4	
10	543 04 47-66	NUT	4	
11	515 98 41-01	SILICONE WASHER	4	
12	521 88 67-01	WASHER	4	
13	574 44 10-01	E-BOX DOOR KIT	1	1
14	516 05 98-01	LOCK	2	1, 13
15	732 25 18-01	LOCK NUT	4	
16	735 21 64-01	TOOTH WASHER	8	
17	735 11 53-01	LOCK WASHER	1	

C1

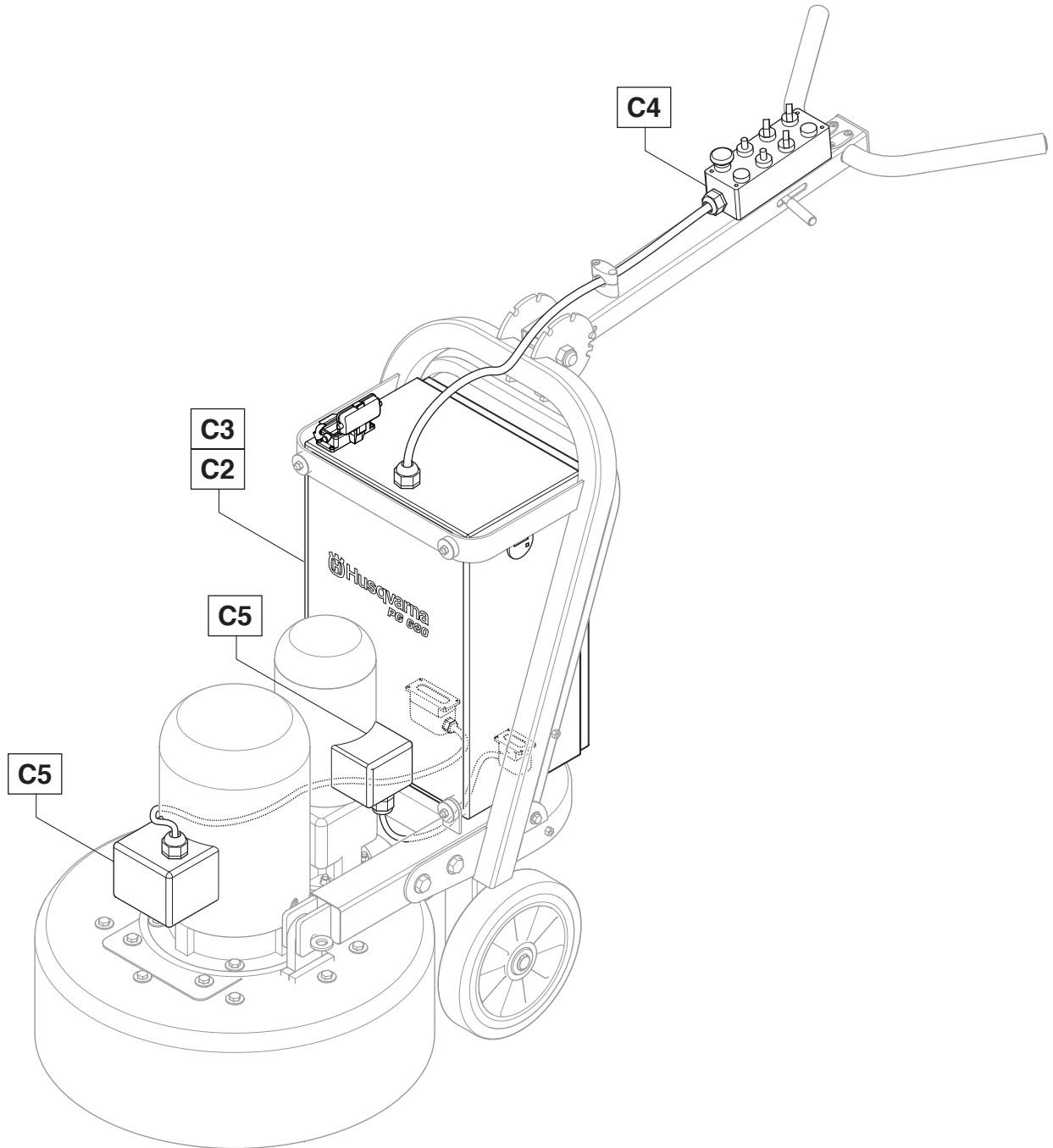

C2

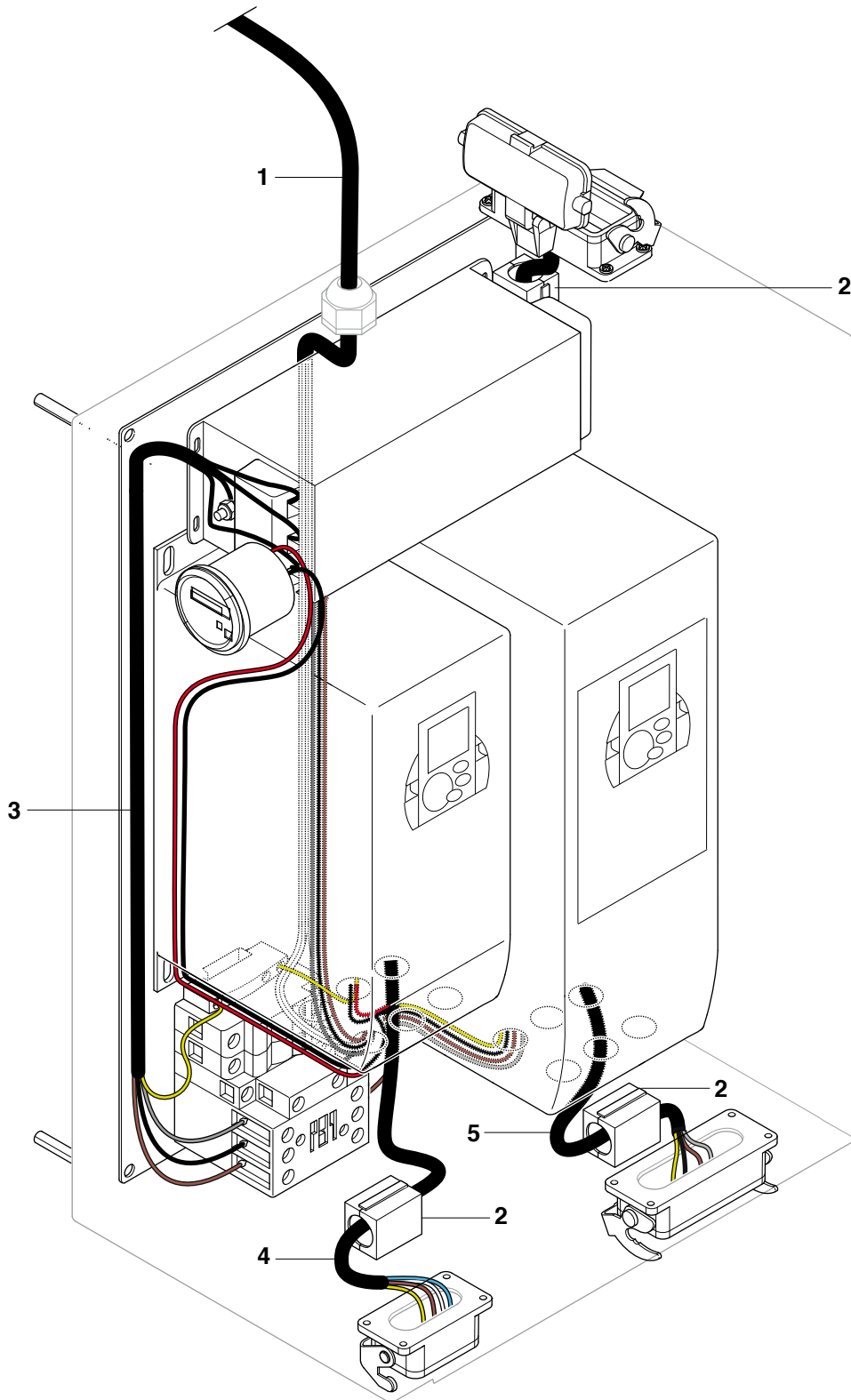

Pos.	Part No.	Description	Quantity	Notes
1	502 54 42-01	CONTROL PANEL LOOM	1	
2	504 71 72-01	FERRITE	3	
3a	516 05 77-01	CONNECTION CABLE CE	1	
3b	516 05 77-02	CONNECTION CABLE UL	1	
4a	516 05 76-01	CABLE CE	1	
4b	516 05 76-02	CABLE UL	1	
5	516 05 75-01	CABLE CE	1	
5b	516 05 75-02	CABLE UL	1	

C3

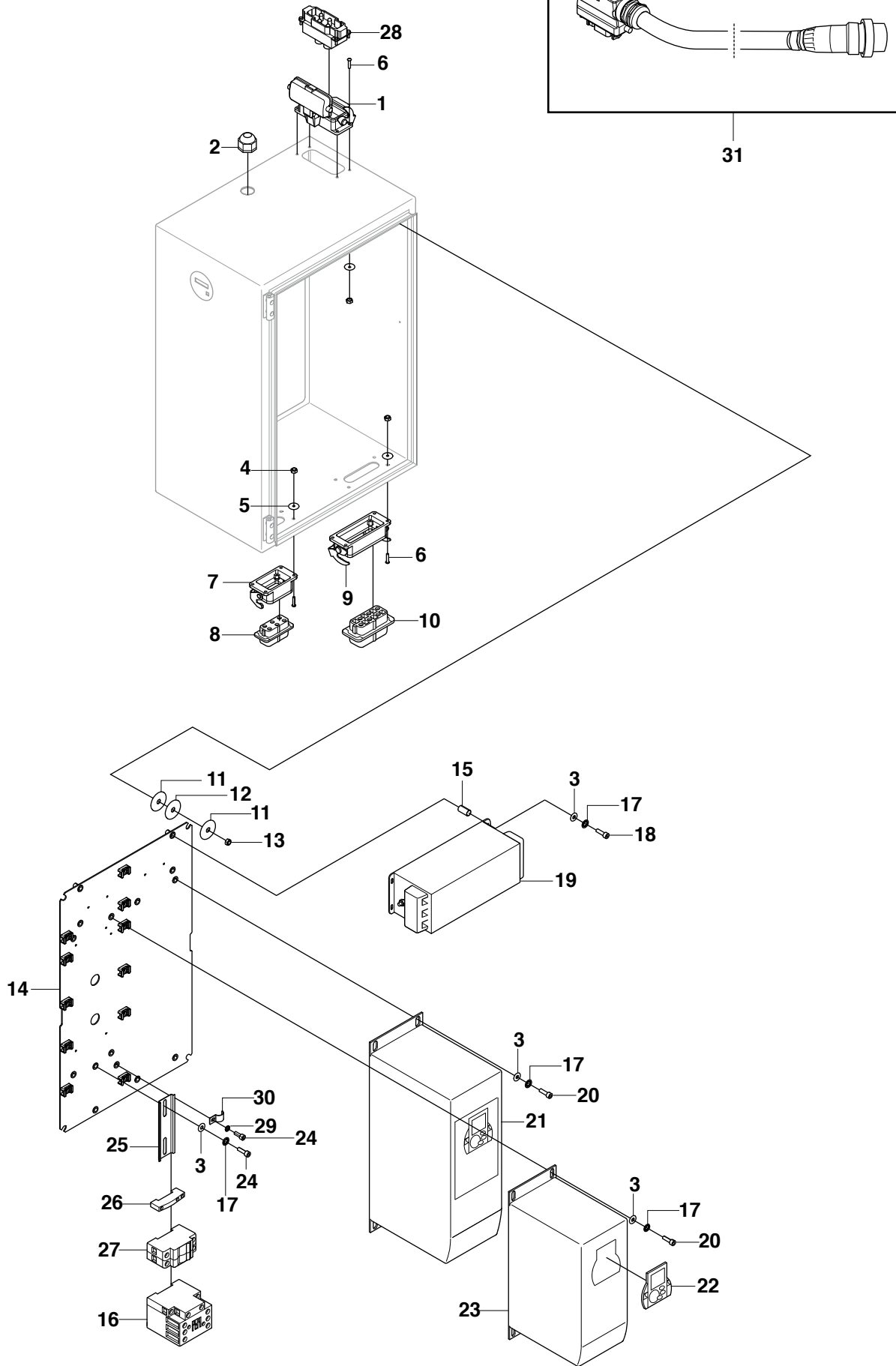

Pos.	Part No.	Description	Quantity	Notes
1	516 06 06-02	HOUSING	1	
2	502 54 39-01	GLAND	2	
3	734 11 54-41	WASHER	14	
4	732 25 12-01	NUT	12	
5	734 11 36-01	WASHER	12	
6	724 12 93-51	SCREW	12	
7	516 06 04-01	HOUSING	1	
8	516 06 05-01	FEMALE PLUG	1	
9	516 06 06-01	HOUSING	1	
10	516 06 07-01	FEMALE PLUG	1	
11	521 88 67-01	WASHER	8	
12	516 06 01-01	RUBBER WASHER	8	
13	732 25 18-01	NUT	4	
14	574 44 12-01	PLATE KIT ASSY	1	
15	504 75 81-01	SPACER	4	
16	502 54 36-01	CONTACTOR BLOCKS	1	
17	735 11 53-01	WASHER	14	
18	725 53 80-01	SCREW	4	
19	504 71 71-01	FILTER	1	Only for CE
20	725 53 70-51	SCREW	8	
21	502 54 25-01	FREQUENCY INVERTER	1	
22a	516 06 10-01	NXL DISPLAY PANEL	2	
22b	505 46 40-01	NXS DISPLAY PANEL	2	
23	502 54 26-01	FREQUENCY INVERTER	1	
24	725 53 68-01	SCREW	3	
25	516 06 11-01	RAIL	1	
26	502 54 38-01	EARTH TERMINALS	1	
27	502 54 37-01	CIRCUIT BREAKER	1	
28	504 76 25-01	CONNECTOR	1	
29	735 21 53-01	TOOTH WASHER	1	
30	504 75 84-01	CLAMP	1	
31a	574 44 13-01	CABLE KIT EU	1	
31b	574 44 13-02	CABLE KIT AU	1	
31c	574 44 13-03	CABLE KIT US	1	

C4

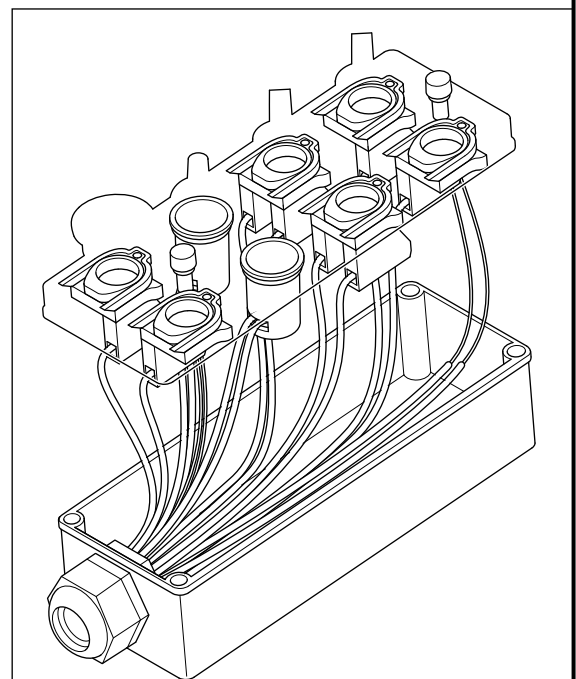
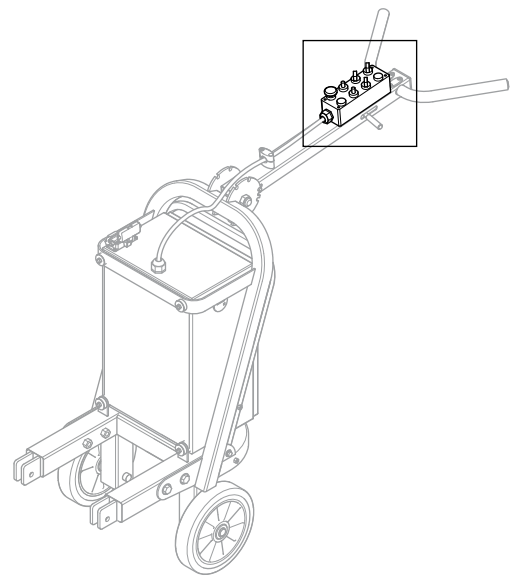
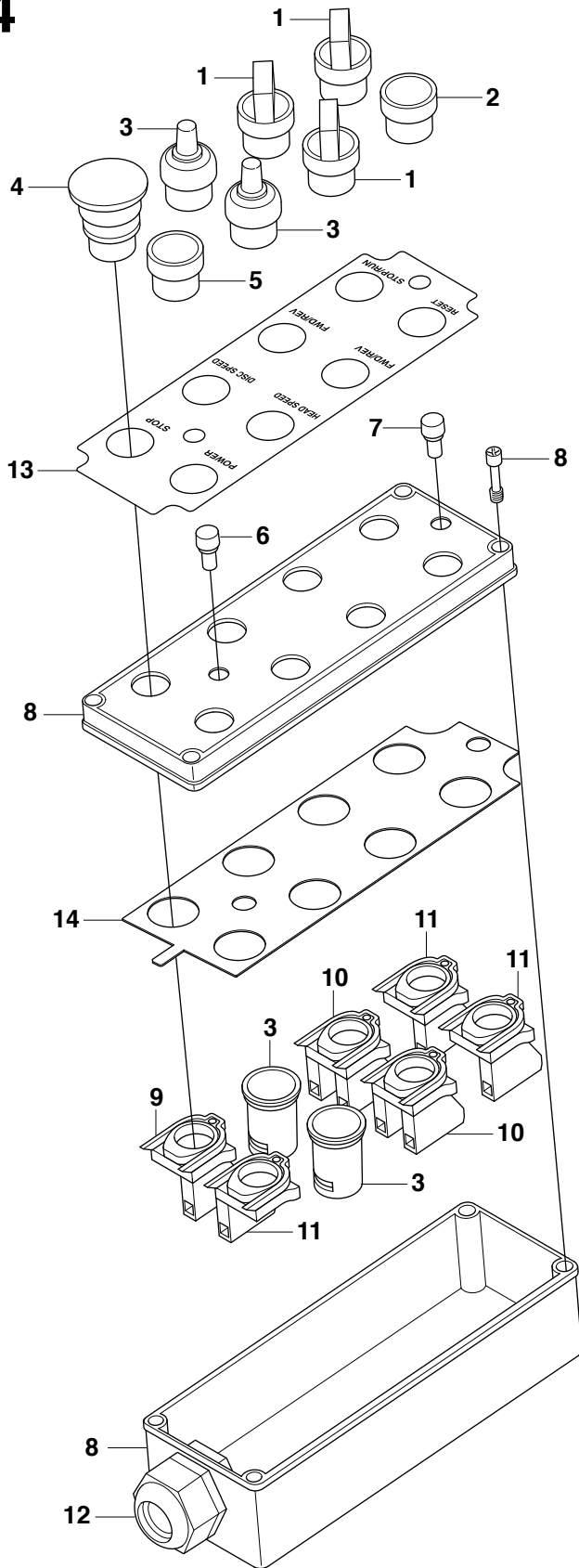

Pos.	Part No.	Description	Quantity	Notes
1	504 73 86-01	SWITCH	3	
2	504 73 88-01	RESET BUTTON	1	
3	502 54 29-01	POTENTIOMETER	2	
4a	504 73 94-01	EMERGENCY STOP BUTTON	1	
5	504 73 90-01	POWER BUTTON	1	
6	504 73 97-01	RED LIGHT INDICATOR	1	
7	504 73 96-01	GREEN LIGHT INDICATOR	1	
8	502 54 46-01	CONTROL PANEL	1	
9a	504 73 95-01	BUTTON BODY	1	
10	504 73 87-01	SWITCH BODY	2	
11	504 73 89-01	BUTTON BODY	3	
12	502 54 39-01	GLAND	1	
13	502 54 33-01	FACE PLATE	1	
14	504 75 82-01	EARTHING PLATE	1	

C5

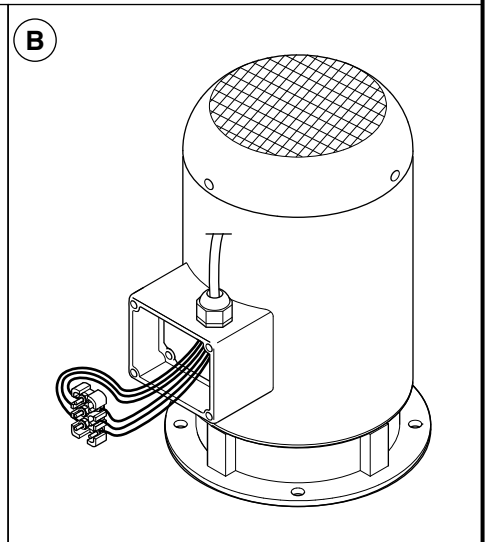
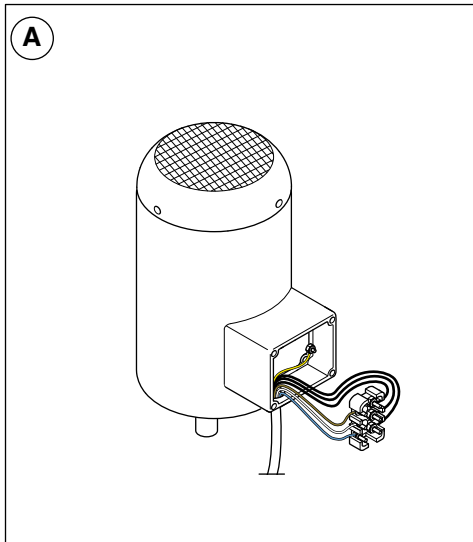
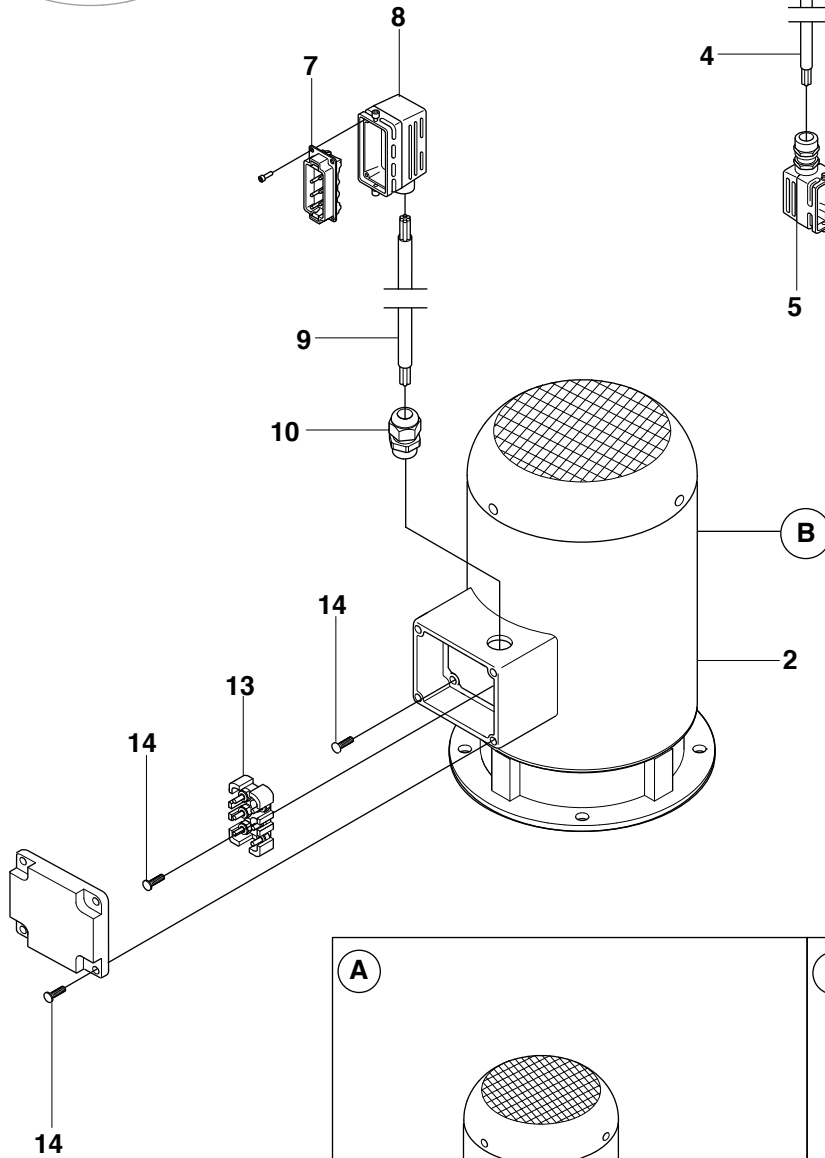
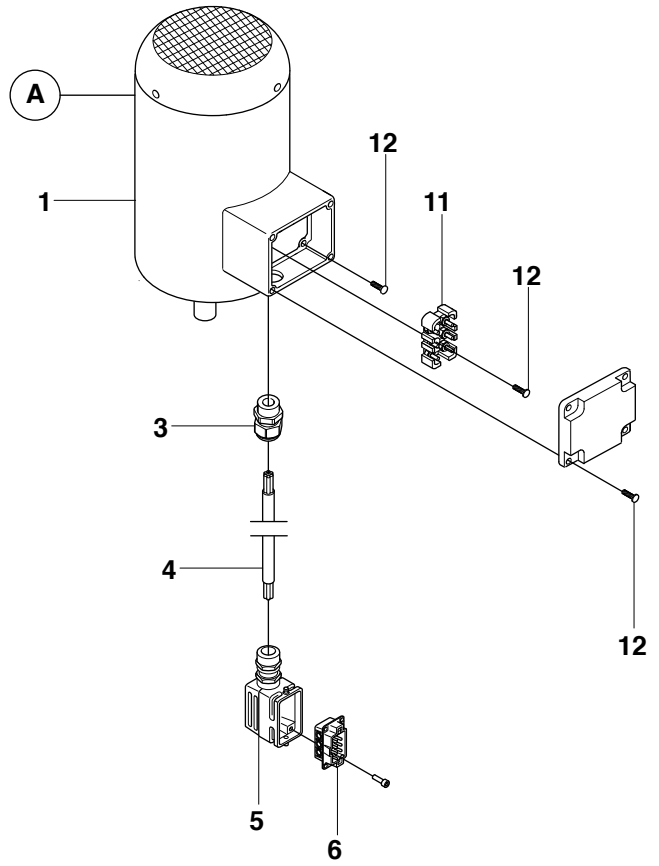
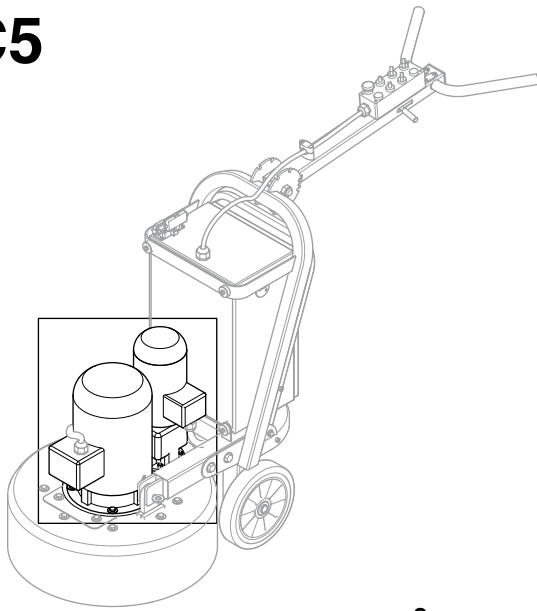

Pos.	Part No.	Description	Quantity	Notes
1	502 53 57-01	PIANETARY MOTOR	1	
2	502 53 52-01	MAIN MOTOR	1	
3	516 06 12-01	GLAND	1	
4a	504 74 03-01	CABLE CE	1	
4b	504 74 03-02	CABLE UL	1	
5	516 06 13-01	HOOD	1	
6	516 06 14-01	MALE PLUG	1	
7	516 06 15-01	MALE PLUG	1	
8	516 06 16-01	HOOD	1	
9a	516 06 17-01	CABLE CE	1	
9b	516 06 17-02	CABLE UL	1	
10	516 06 18-01	GLAND	1	
11	516 06 19-01	TERMINAL BLOCK	1	
12	723 13 27-51	SCREW	9	
13	516 06 20-01	TERMINAL BLOCK	1	
14	724 13 68-51	SCREW	9	